



Unique Structure
Multi-Round Filter Housing

GEX-TA_{Type}

Major Applications

Chemical/ Electronics

Main Specifications

Design pressure: 0.69MPa

Main materials: SUS304

Inner and Outer surfaces finishing:
Buffing (# 250)

Features

- Designed for even fluid flow from the top of the filter
- Designed to reduce excess space
- Designed for maintenance
Clamp band type adopted

Advantages

- Fluid does not easily stagnate.
- Reduction of liquid loss
- Easy disassembly and cleaning

End Cap Code

Code CZ

Code PZ

Code F



Ordering Information

Product Type

GEX-TA-

Filter length

2 5 0

▼
250 = 250mm
500 = 500mm
750 = 750mm

Number of installed filters

- 0 3 -

▼
03 = 3pcs
06 = 6pcs

O-Ring

E

▼
S = Silicone
E = EPDM
N = NBR
V = FKM

End Cap Code

F

▼
F = Code CZ, PZ, F

Structure

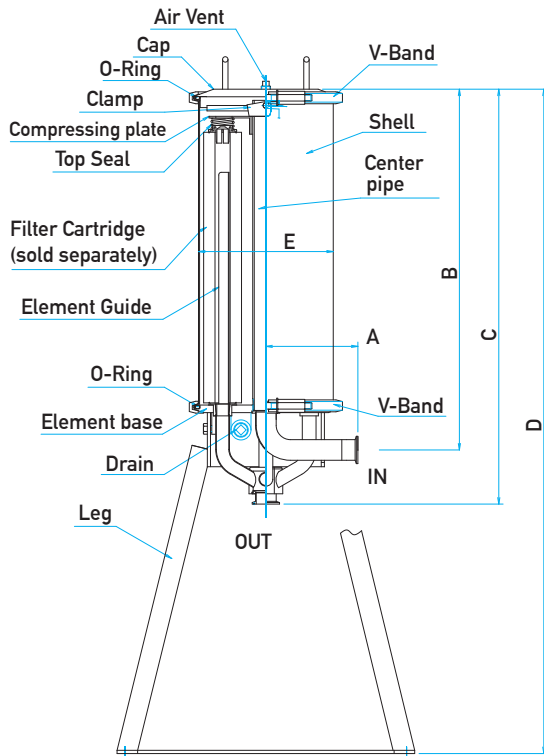

Specifications

Filter length	250 / 500 / 750 mm
End Cap Code	Code CZ, PZ, F
Shell	SUS304
V-Band	SCS13
Air Vent Plug	SUS304
Cap	SUS304
O-Ring	NBR, EPDM, Silicone, FKM
Clamp	SUS304
Materials	Compressing plate
	SUS304
	STD Spring
	SUS316
	STD Top Seal
	Polypropylene
	Element Guide
	SUS304
	Center pipe
	SUS304
	Element base
	SUS304
	Drain Plug
	SUS304
	Leg
	SUS400 (Surface Coating)
Surface finishing	Inner/outer surfaces: Buffing (#250)
	*Excluding some center pipe inner surfaces, etc.
Design pressure	0.69MPa at 40°C (100psi at 104°F)

*If you require a housing made of a material other than the above (SUS316L, etc.) or a filter length or shape other than the above, please inquire separately.

Dimension

	A	B	C	D	E	Connection diameter	Drain	Air Vent
GEX-TA-250-03-F	130mm	395mm	485mm	970mm	187mm	IDF 1S • Ferrule	Rc3/4	Rp3/8
GEX-TA-250-06-F	170mm	417mm	517mm	978mm	249mm	IDF 1.5S • Ferrule	Rc3/4	Rp3/8
GEX-TA-500-03-F	130mm	645mm	735mm	1220mm	187mm	IDF 1S • Ferrule	Rc3/4	Rp3/8
GEX-TA-500-06-F	170mm	667mm	767mm	1228mm	249mm	IDF 1.5S • Ferrule	Rc3/4	Rp3/8
GEX-TA-750-03-F	130mm	895mm	985mm	1470mm	187mm	IDF 1S • Ferrule	Rc3/4	Rp3/8
GEX-TA-750-06-F	170mm	917mm	1017mm	1478mm	249mm	IDF 1.5S • Ferrule	Rc3/4	Rp3/8

*Other connection diameters, shapes, and positions are also available. Please contact us for details.

*The contents of the catalog are subject to change without notice.

*The performance data listed in the catalog are Typical values obtained under specific conditions based on our tests.

*When purchasing a filter housing, be sure to check whether the filtration conditions (fluid, operating temperature, operating pressure, installation location, etc.) are within the housing specifications.

ROKI GROUP International Pte. Ltd.

6-20-12, Minami-Oi, Shinagawa-ku Tokyo, 140-0013 Japan
TEL: +81-3-5764-1131 FAX: +81-3-5764-0681

www.rokiglobal.com

Manufacturing is based on our Quality Management Systems that meet ISO9001 standards.

Scope

Design, Development, manufacture, and sales of filter cartridges, housings and filtration equipment.



JQA-QMA16323

MS CM009

6th Issue
GEX-TA220204E